



SUPREME

MARBLE BRIDGE SAWS

CONTROL BOARD

- The control board includes:
- Switch with release coil.
 - Overheat protection with manual reset in the event of the disk jamming.
 - Red light for net connection.
 - Green light for machine on function.
 - Laser instrument for the maximum cutting precision.

CUTTING DEPTH

A graduated scale measures the adjustment of the cutting depth by locking the engine group.

STORAGE

Built to reduce at the maximum the encumbrance during the carriage and above all the storage space.

Designed and made in Italy

Article	SUPREME 55		SUPREME 85		SUPREME 100		SUPREME 120		SUPREME 150		SUPREME 200	
	Art. 8055	Art. 80551	Art. 8085	Art. 80851	Art. 8100	Art. 81001	Art. 8120	Art. 81201	Art. 8150	Art. 81501	Art. 8200	Art. 82001
CUTTING DISK Ø300 (int ø25,4mm.)	Optional		Optional		Optional		Optional		Optional		Optional	
ENGINE	Single phase 230V/50Hz 3Hp/2,2Kw		Single phase 230V/50Hz 3Hp/2,2Kw		Single phase 230V/50Hz 3Hp/2,2Kw		Single phase 230V/50Hz 3Hp/2,2Kw		Single phase 230V/50Hz 3Hp/2,2Kw		Single phase 230V/50Hz 3Hp/2,2Kw	
ROTATION SPEED	2800 rpm.		2800 rpm.		2800 rpm.		2800 rpm.		2800 rpm.		2800 rpm.	
AMPEROMETRICAL PROTECTION	13 A		13 A		13 A		13 A		13 A		13 A	
MAX CUTTING LENGTH	550 mm.		850 mm.		1000 mm.		1200 mm.		1500 mm.		2000 mm.	
MAX CUTTING DEPTH AT 90°	85 mm.		85 mm.		85 mm.		85 mm.		85 mm.		85 mm.	
MAX CUTTING DEPTH WITH 2 RUNS	135 mm.		135 mm.		135 mm.		135 mm.		135 mm.		135 mm.	
MAX CUTTING DEPTH AT 45°	60 mm.		60 mm.		60 mm.		60 mm.		60 mm.		60 mm.	
WORKING TABLE SIZE	550 x 620 mm.		850 x 620 mm.		850 x 620 mm.		1200 x 620 mm.		1500 x 620 mm.		2050 x 625 mm.	
WATER RECYCLING PUMP TYPE	S3 standard		S3 standard		S3 standard		S3 standard		S3 standard		S3 standard	
KIT WHEELS	Optional	Standard	Optional	Standard	Optional	Standard	Optional	Standard	Optional	Standard	Optional	Standard
LASER INSTRUMENT	Optional	Standard	Optional	Standard	Optional	Standard	Optional	Standard	Optional	Standard	Optional	Standard
DIMENSION MACHINE IN SERVICE	770x1280x h. 1100 mm.		770x1580x h. 1100 mm.		770x1730x h. 1100 mm.		770x1930x h. 1100 mm.		770x2230x h. 1100 mm.		770x2710x h. 1280 mm.	
DIMENSION MACHINE IN STOCK	720x1300x h. 1000 mm.		720x1600x h. 1000 mm.		720x1750x h. 1000 mm.		720x1950x h. 1000 mm.		720x2250x h. 1000 mm.		720x2750x h. 1000 mm.	
DIMENSION 3 MACHINES ON PALLET	720x1300x h. 2260 mm.		720x1600x h. 2260 mm.		720x1750x h. 2260 mm.		720x1950x h. 2260 mm.		720x2250x h. 2260 mm.		720x2750x h. 2260 mm.	
NET WEIGHT	75 Kg.		80 Kg.		83 Kg.		86 Kg.		92 Kg.		99 Kg.	

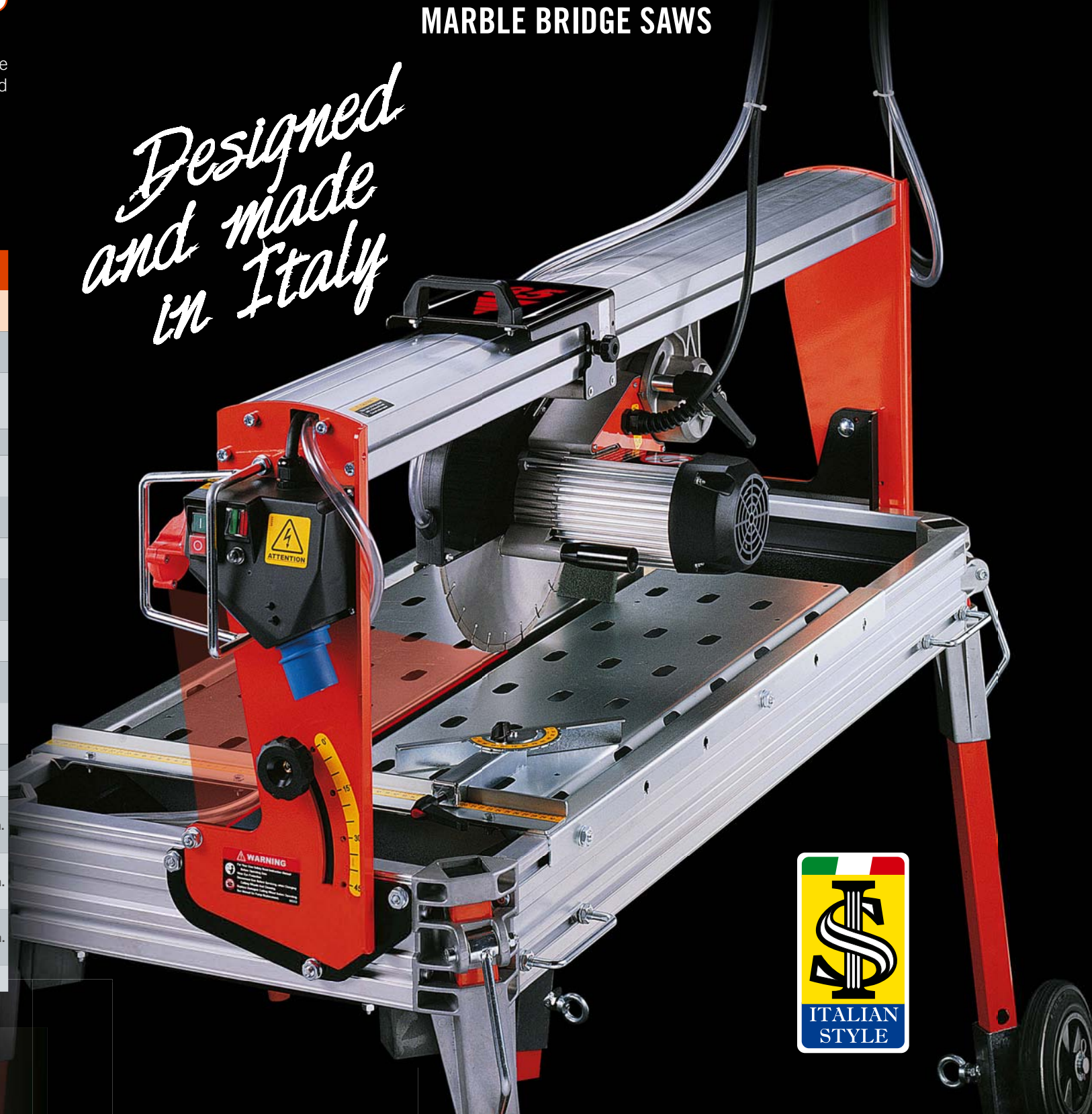

BATTIPAV™

MACCHINE PER EDILIZIA | MACHINES FOR BUILDING

Z. i. 2 - Via Cavatorta, 6/1 | 48010 Cotignola (Ra) | ITALY
 Tel. +39 0545 40004 | Fax +39 0545 41724
 www.battipav.com | sales@battipav.com

AUTHORIZED DEALER:



July 2012

APPLICATION

Built to cut natural-stones, granite and marble slabs with diamond disk Ø 300 mm.

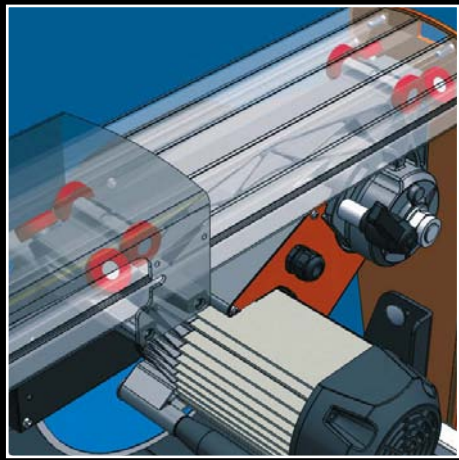

The carriage engine group slides with 8 ball-bearings on interchangeable stainless steel track. So doing the sliding is very fast and precise.



Position for 45° angle cuts.



The **CUTTING PROGRESS SYSTEM** with **HANDWHEEL** adjusts the movement of the cutting head forward or behind.

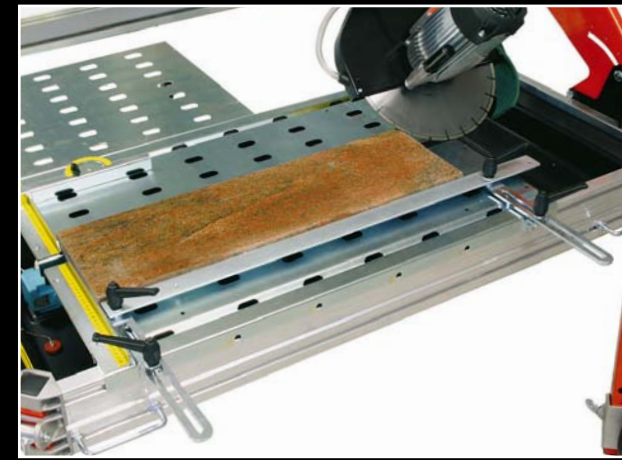

SIDE TILE SUPPORT

Made to have the top precision during the execution of straight and angled cuts on slabs of large size. Adjustable angle-shot cut.

Optional for the models: 85, 100, 120, 150 and 200



SIDE TABLE WITH ROLLERS

Composed by 5 galvanized rollers mounted on ball-bearings. Dimension: 800 x 600 mm. (Optional)

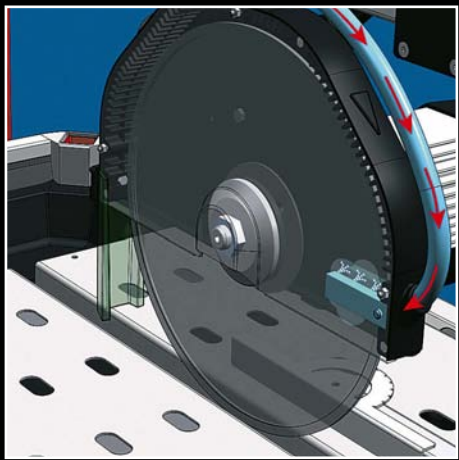

Spray system

DISK'S LUBRICATION

wdec

WATER DECANTING SYSTEM



ORIGINAL RECYCLING PUMP

FastLEG

LEG FASTENING SYSTEM